

Silo Mount Vessel Weighing Assembly



- Low cost installation
- Stainless load cell
- Sealed to IP68
- Allows vessel expansion / contraction
- Five sizes
- High accuracy
- High resistance to off axis loads
- Integral lift off prevention

The Silo Mount weighing system from Elite Transducers Ltd offers a complete vessel weighing solution incorporating lift off prevention and vessel expansion without compromising accuracy.

It features a fully welded sensor and is manufactured from high tensile stainless steel type 17-4-PH for enhanced durability and corrosion resistance.

The sensor becomes an integral part of your assembly and eliminates the need for vessel restraints or check rods.

Intrinsically safe certification is also available to ATEX / IECEx Standards (certified for use in gas and dust zones).

Our exacting build standards and test procedures ensure that all Elite Transducers Ltd Silo Mount systems can be offered with a three year warranty.

We can also offer customised designs suited to your exact specification as well as a selection of optional accessories including stainless steel brackets and a range of instrumentation.

Capacities	0.5,1,2,5,7.5,10,15,20,30,50,75,100	tonne
Full Load Output	2.0 ($\pm 0.25\%$)	mV/V
Zero Load Output	$< \pm 2.0$	%
Excitation (Max)	10 (15)	V
Accuracy (combined error)	< 0.05	%
Repeatability	< 0.01	%
Input Resistance	750 (± 20)	Ω
Output Resistance	700 (± 2)	Ω
Compensated Temp. Range	-10 to +50	$^{\circ}\text{C}$
Operating Temp. Range	-25 to +70	$^{\circ}\text{C}$
Temp. Coefficient on Zero	< 0.005	% Capacity/ $^{\circ}\text{C}$
Temp Coefficient on Span	< 0.003	% Capacity/ $^{\circ}\text{C}$
Safe Overload	150	%
Insulation	$> 500 @ 100\text{Vdc}$	M Ω
Environmental Protection	IP68	

Specifications subject to change without notice

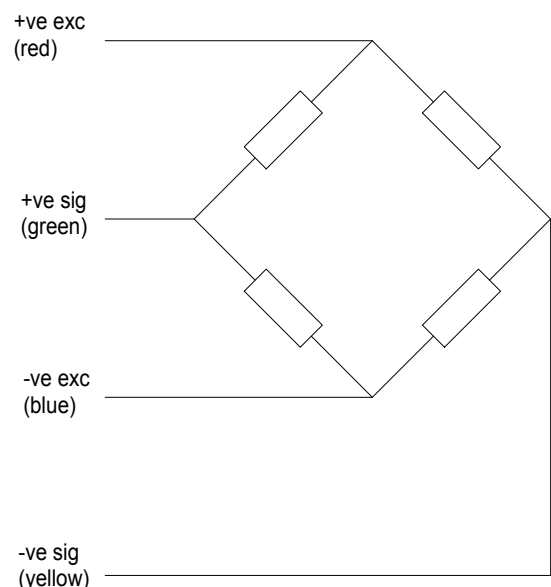

ATEX / IECEx Approved to
Ex ia IIC T6
Ex tD A20 IP68 T85C



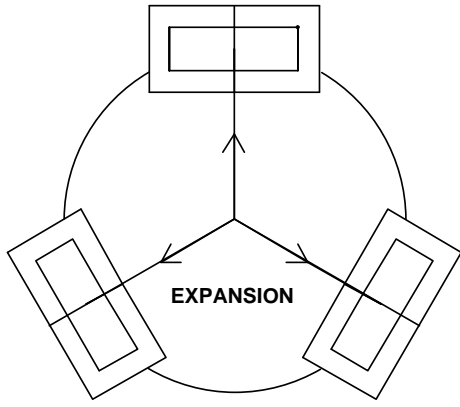

SILO MOUNT 3 LOAD CELL INSTALLATION

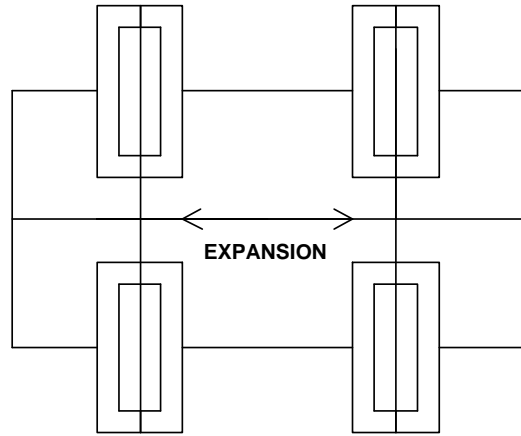

SILO MOUNT 4 LOAD CELL INSTALLATION

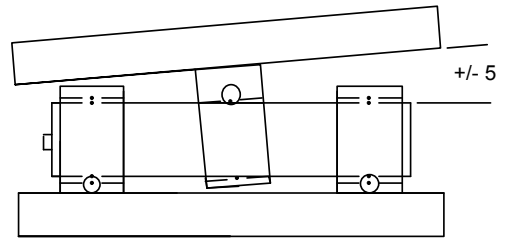
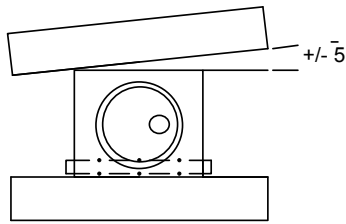

All dimensions in mm

	Capacity	A	B	C	D	E	ØF	No. F	G	Min Exsp
Size 1	1 – 5te	105	150	94	124	88	13	8	12.7	3mm
Size 2	2 – 20te	140	200	125	165	117	18	8	18	4mm
Size 3	10 – 50te	175	280	175	230	162	22	8	25	6mm
Size 4	75te	240	300	190	250	184	26	12	25	6mm
Size 5	100te	250	320	230	300	210	26	12	30	8mm

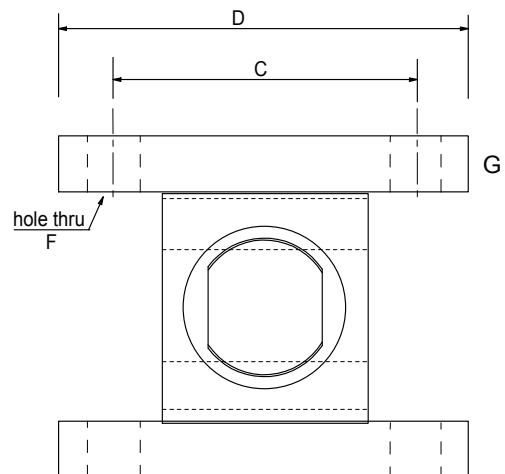
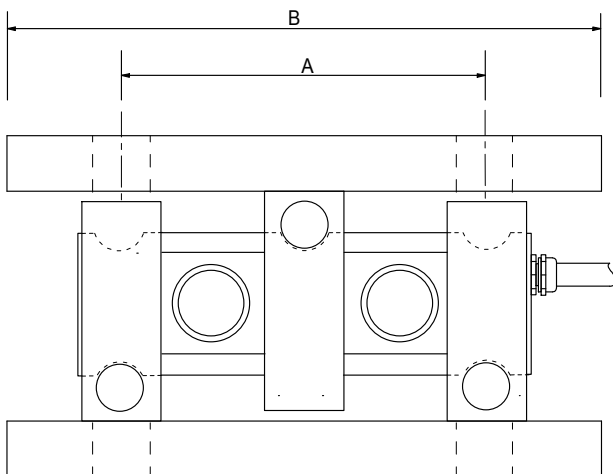

ATEX / IECEx Approved to
Ex ia IIC T6
Ex tD A20 IP68 T85C



Silo Mount Bracket Assembly

Coating Options

Standard Finish

The Silo Mount weighing system from Elite Transducers Ltd has a standard finish applied to the mild steel support brackets. The first step is a zinc phosphate pre-treatment for rust prevention then a black E-Coat is applied. This electrophoretically applied finish ensures a uniform and durable appearance on the brackets.

Options

You can specify any RAL colour to be powder coated over the above finish to give your Silo Mount a stand out appearance.

Processes

Zinc Phosphate

The application of zinc phosphate by immersion provides a fine grained crystalline on the surface of the steel and is an excellent base providing parts with 'bare' rust protection so they do not require immediate painting.

Electrophoretic Paint

Electrophoretic paint (E-Coat) technology is ideal for the application of a uniform organic coating. The electrophoretic deposition of a finish provides a coating of uniform thickness on even the most complex shapes, significantly outperforming both sprayed or dipped finishes. Used widely in the automotive industry for its excellent corrosion resistance an E-Coat is the perfect finish where durability and longevity are key.

Polyester Powder Coat

An additional powder coat is recommended for any application where a high resistance to weathering is required, for example in exposed exterior fittings. This additional coating is well suited to environments where the installation is at temperatures elevated from the ambient as it has a high resistance to yellowing.

For further information about any of these processes or to receive a quotation to suit your specific application please contact us and our team will be happy to help.

ATEX / IECEx Approved to
Ex ia IIC T6
Ex tD A20 IP68 T85C

